



Technical specifications:

Housing	Material	Aluminium
	Colour	Red/bronze mat (anodized)
	Dimension	52 mm x 225,4 mm
Joint	Material	Stainless steel/ aluminium
	Mech. adjustment range	Tilt and pan angle approx. 35°
		Rotation angle approx. 360°
Protective hose	Material	Stainless steel
Camera	Sensor	CMOS
	Video size	1080P@60Hz; 1080P@50Hz
	Video interface	HDMI
	View angle	90° (optional 142°)
Operating voltage	Supply voltage	24 V DC
	Rated current	0,2 A
	Max. current	0,5 A
Additional	Protection class	IP67
	Compressed air supply	1 bar
	Weight	approx. 1,7 kg
	Stainless steel hose	(AISI-316L)
Optional	Length	on request

* only when system is under pressure with a minimum of 0,3 bar

Scope of delivery:

- Camera with sealing air attachment
- Internal ball joint mounting
- Wall mount complete with seal and lock nut
- HDMI-repeater-coupling
- Compressed air connector Ø6 mm
- M12 plug 5-pole A-coded

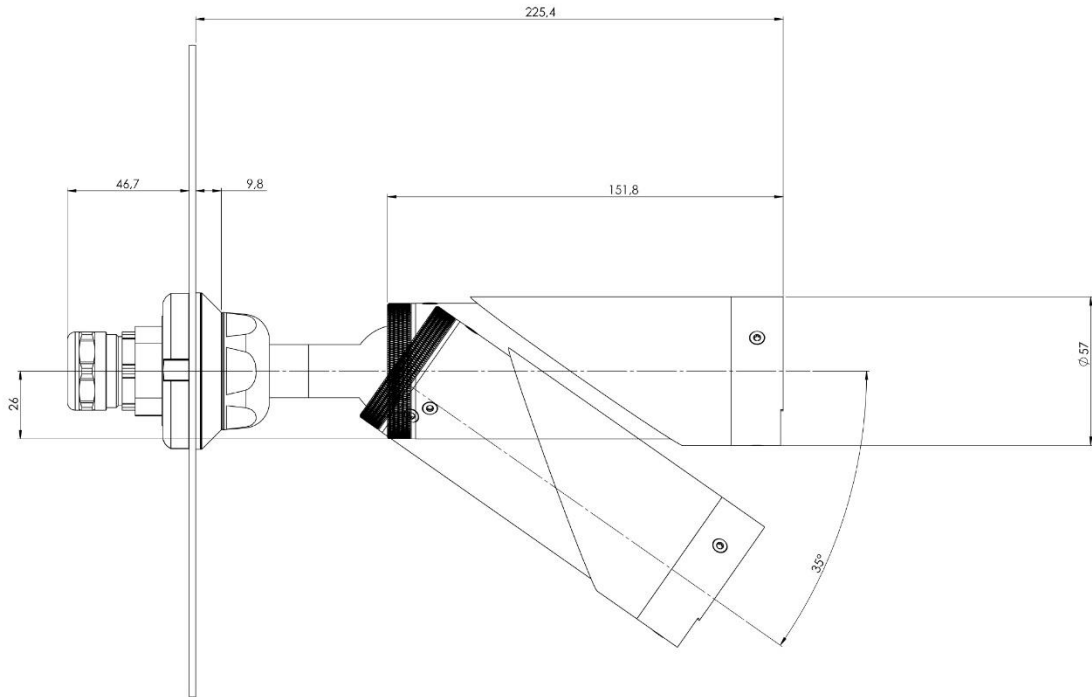

(Je nach Ausrichtung der Kugel)

